

Peso y Dimensiones

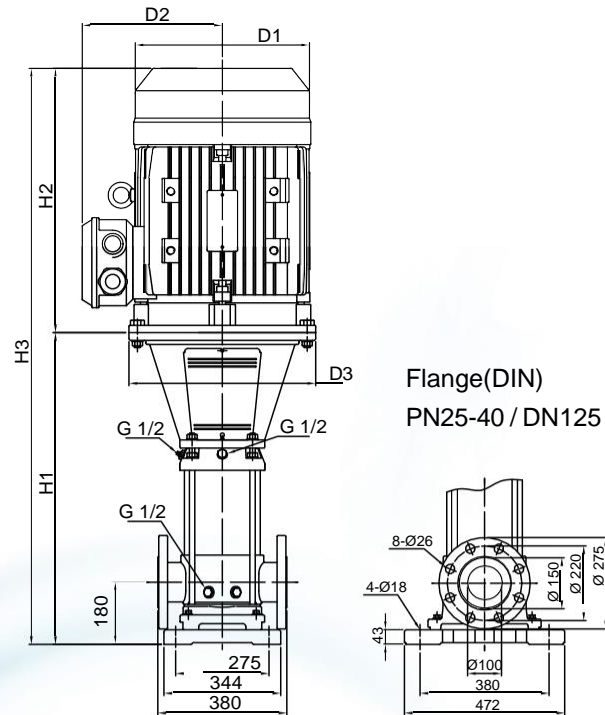

MODELO	HP	ACOPLE	DIMENSIONES Y PESO SERIE VPS - MOTORES IEC									
			H1		H2		D1		D2		PESO NETO	
			in	mm	in	mm	in	mm	in	mm	lbs	kg
TRIFASICO												
VPS 120-1-1	20	160M	-	-	-	-	-	-	-	-	-	-
VPS 120-1	25	160L	33	837	21 3/8	540	12 5/8	318	9 1/2	241	484	220
VPS 120-2-2	40	200L	39 1/8	993	26	660	15 3/8	390	11 5/8	295	772	350
VPS 120-2-1	40	200L	39 1/8	993	26	660	15 3/8	390	11 5/8	295	772	350
VPS 120-2	50	200L	39 1/8	993	26	660	15 3/8	390	11 5/8	295	812	368
VPS 120-3-2	60	225M	-	-	-	-	-	-	-	-	-	-
VPS 120-3-1	60	225M	45 3/8	1152	27 1/4	690	17 5/8	446	13	325	1001	454
VPS 120-3	75	250M	46 3/8	1178	30 3/8	770	19 1/8	485	14	355	1267	575
VPS 120-4-2	75	250M	-	-	-	-	-	-	-	-	-	-
VPS 120-4-1	100	280S	52 5/8	1334	33 3/8	845	21 3/4	550	16 1/4	410	1546	701
VPS 120-4	100	280S	-	-	-	-	-	-	-	-	-	-
VPS 120-5-2	100	280S	58 5/8	1489	33 3/8	845	21 3/4	550	16 1/4	410	1568	711

Todas las medidas son de referencia. Los valores podrán cambiar según el modelo del motor.
 Todas las medidas y curvas de prestaciones son válidas para la serie VPC.

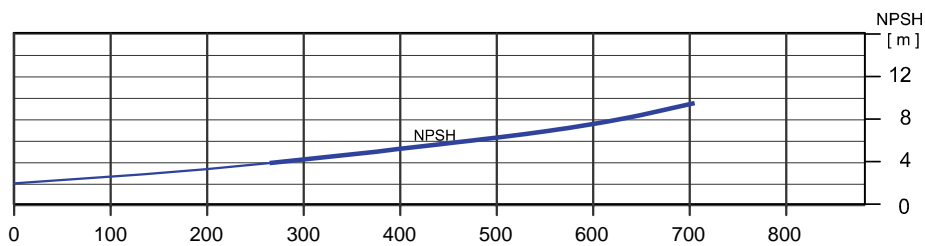
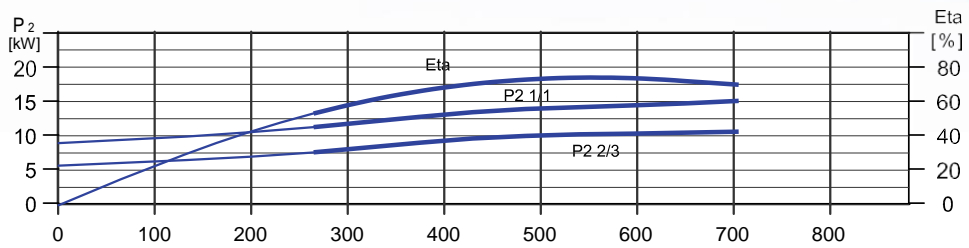
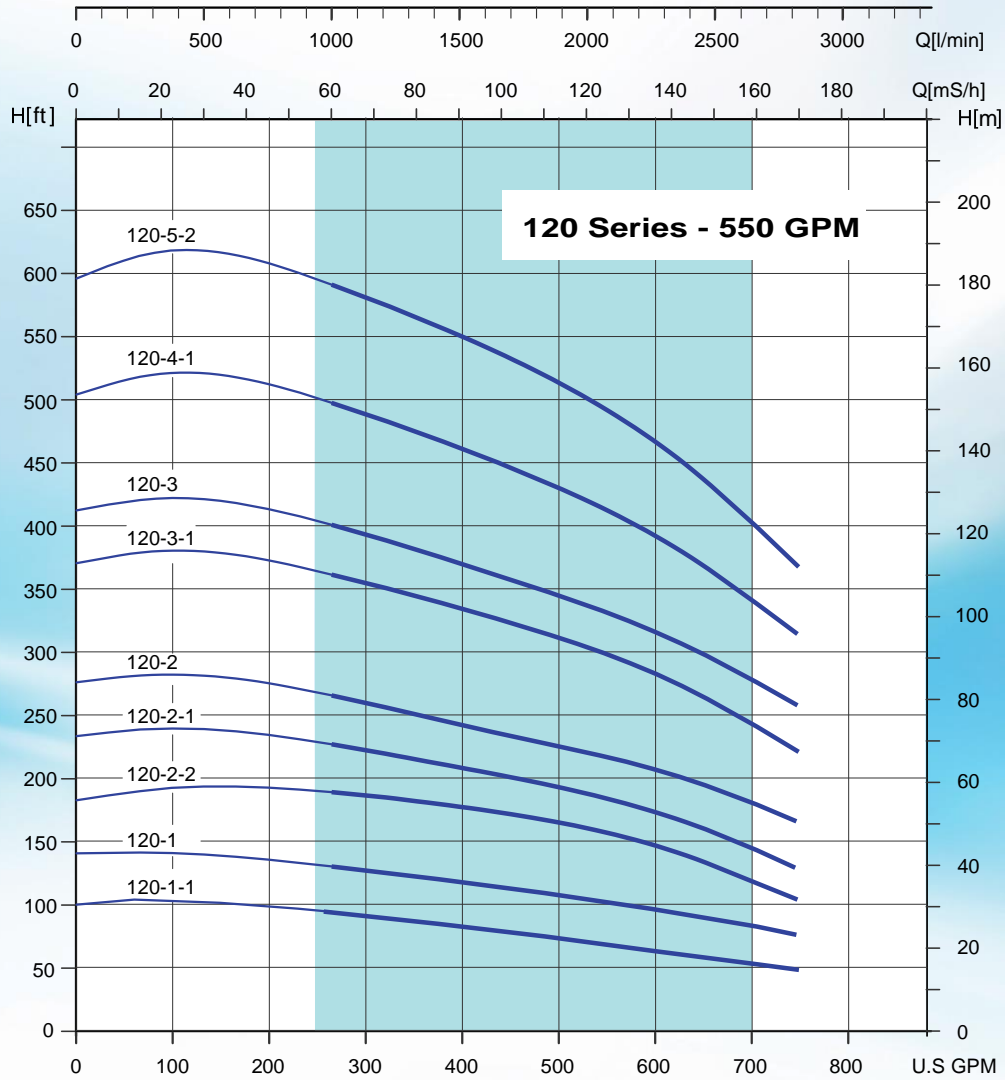

Peso y dimensiones

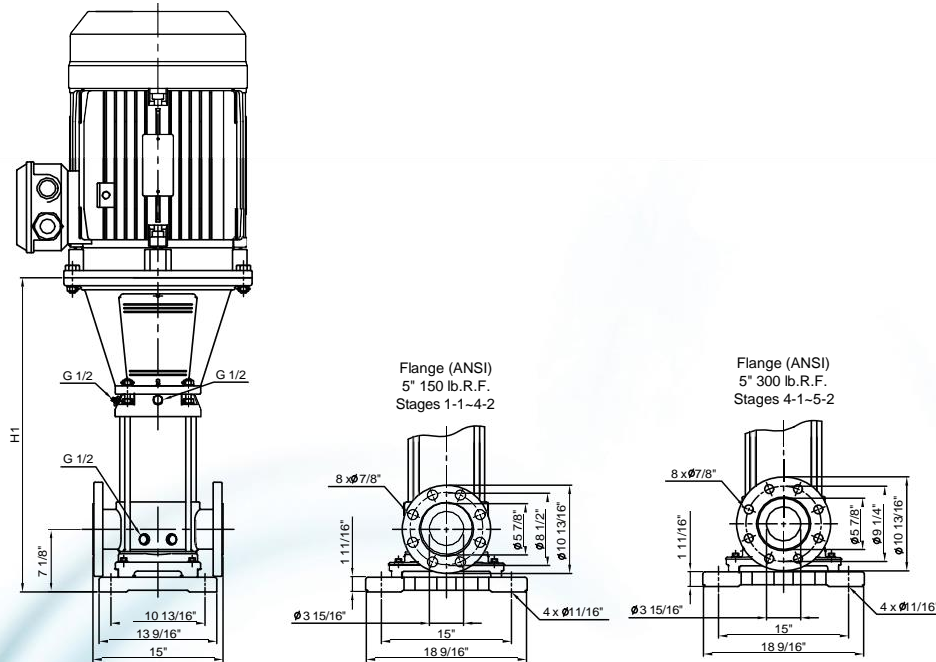

MODELO	HP	ACOPLE	MOTOR ODP	MOTOR TEFC	DIMENSIONES Y PESO SERIE VPS - MOTORES NEMA																					
					H1		H2		H2		D1		D1		D2		D2		D3		PESO NETO					
					HIDRAULICA		ODP		TEFC		ODP		TEFC		ODP		TEFC		ODP		TEFC					
					in	mm	in	mm	in	mm	in	mm	in	mm	in	mm	in	mm	in	mm	lbs	kg	lbs	kg		
TRIFASICO																										
VPS 120-1-1	20	254TC	MVB 200H36O	MVB 200H36T	33	837	18 1/4	464	20	503	11 1/2	293	13	329	9 1/2	242	10 1/8	256	9 1/2	241	9 1/8	231	185	84	229	104
VPS 120-1	25	284TSC	-	MVB 250H36T	33	837	-	-	19 1/4	487	-	-	13	329	-	-	11 5/8	293	-	-	11 1/4	285	-	-	283	129
VPS 120-2	50	326TSC	-	MVB 500H36T	39 1/8	993	-	-	25 1/8	636	-	-	17	429	-	-	14 3/4	372	-	-	13 1/2	341	-	-	450	205
VPS 120-3-2	60	364TSC	-	MVB 600H36T	45 1/4	1148	-	-	27 5/8	700	-	-	19 1/2	496	-	-	18 1/8	460	-	-	13	330	-	-	736	334
VPS 120-3-1	60	364TSC	-	MVB 600H36T	45 1/4	1148	-	-	27 5/8	700	-	-	19 1/2	496	-	-	18 1/8	460	-	-	13	330	-	-	736	334
VPS 120-3	75	365TSC	-	MVB 750H36T	45 3/4	1160	-	-	27 5/8	700	-	-	19 1/2	496	-	-	18 1/8	460	-	-	13	330	-	-	747	339
VPS 120-4-2	75	365TSC	-	MVB 750H36T	52	1315	-	-	27 5/8	700	-	-	19 1/2	496	-	-	18 1/8	460	-	-	13	330	-	-	747	339

- No está disponible.
 Todas las medidas son de referencia. Los valores podrán cambiar según el modelo del motor.
 Todas las medidas y curvas de prestaciones son válidas para la serie VPC.