

## Peso y Dimensiones

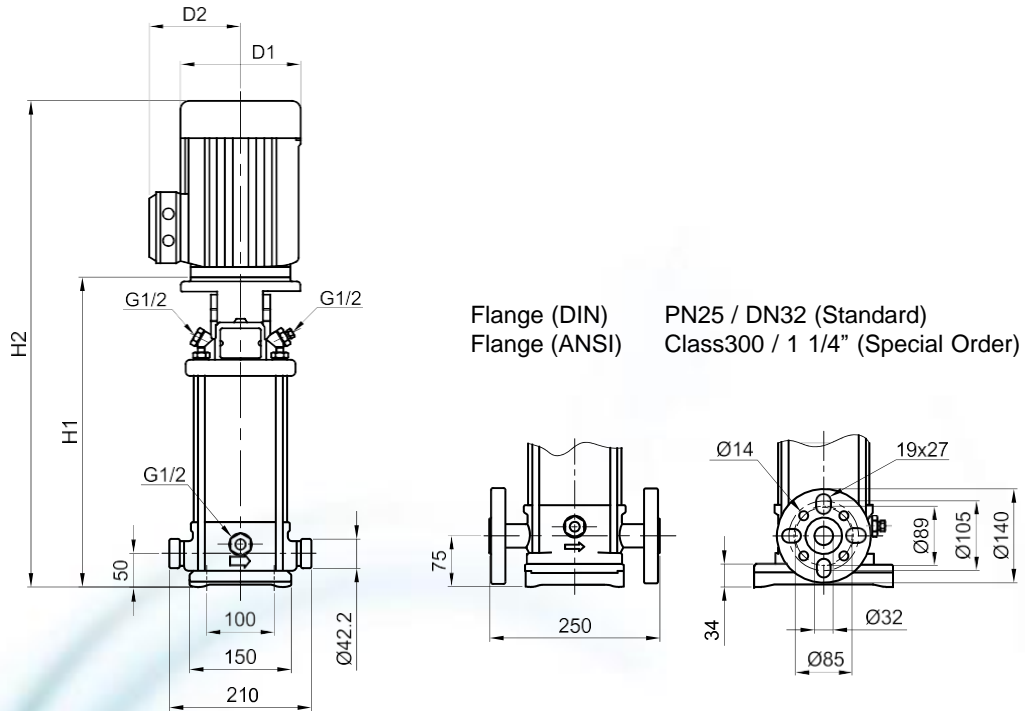

MODELO	HP	ACOPLE	DIMENSIONES Y PESO SERIE VPS - MOTORES IEC									
			H1		H2		D1		D2		PESO NETO	
			in	mm	in	mm	in	mm	in	mm	lbs	kg
MOTOR TRIFASICO												
VPS 1-2	0.5	71	11 1/8	282	19	477	5 5/8	141	4 5/8	115	45	21
VPS 1-3	0.5	71	11 1/8	282	19	477	5 5/8	141	4 5/8	115	45	21
VPS 1-4	0.5	71	12	300	19 1/2	495	5 5/8	141	4 5/8	115	46	21
VPS 1-5	0.75	80 M	12 5/8	318	20 1/4	513	5 5/8	141	4 5/8	115	48	22
VPS 1-6	0.75	80 M	13 1/4	336	21	531	5 5/8	141	4 5/8	115	49	22
VPS 1-7	1	80A	14 1/4	360	23 1/2	595	5 5/8	141	4 5/8	115	54	25
VPS 1-8	1	80A	15	378	24 1/4	613	5 5/8	141	4 5/8	115	55	25
VPS 1-9	1	80A	15 5/8	396	25	631	5 5/8	141	4 5/8	115	56	25
VPS 1-10	1.5	80B	16 3/8	414	27 3/4	703	7	177	5 5/8	141	71	33
VPS 1-11	1.5	80B	17 1/8	432	28 1/2	721	7	177	5 5/8	141	72	33
VPS 1-12	1.5	80B	17 3/4	450	29 1/8	739	7	177	5 5/8	141	73	33
VPS 1-13	1.5	80B	18 1/2	468	30	757	7	177	5 5/8	141	74	34
VPS 1-15	2	90S	20 1/2	520	32 1/8	815	7	177	5 5/8	141	84	39
VPS 1-17	2	90S	22	556	33 1/2	851	7	177	5 5/8	141	86	39
VPS 1-19	3	90L	23 3/8	592	35	887	7	177	5 5/8	141	92	42
VPS 1-21	3	90L	24 3/4	628	36 3/8	923	7	177	5 5/8	141	93	43
VPS 1-23	3	90L	26 1/4	664	38	959	7	177	5 5/8	141	95	43
VPS 1-25	3	90L	27 5/8	700	39 1/4	995	7	177	5 5/8	141	97	44
VPS 1-27	4	100L	29 1/4	741	41 5/8	1057	8	197	6	147	117	53

Todas las medidas son de referencia. Los valores podrán cambiar según el modelo del motor

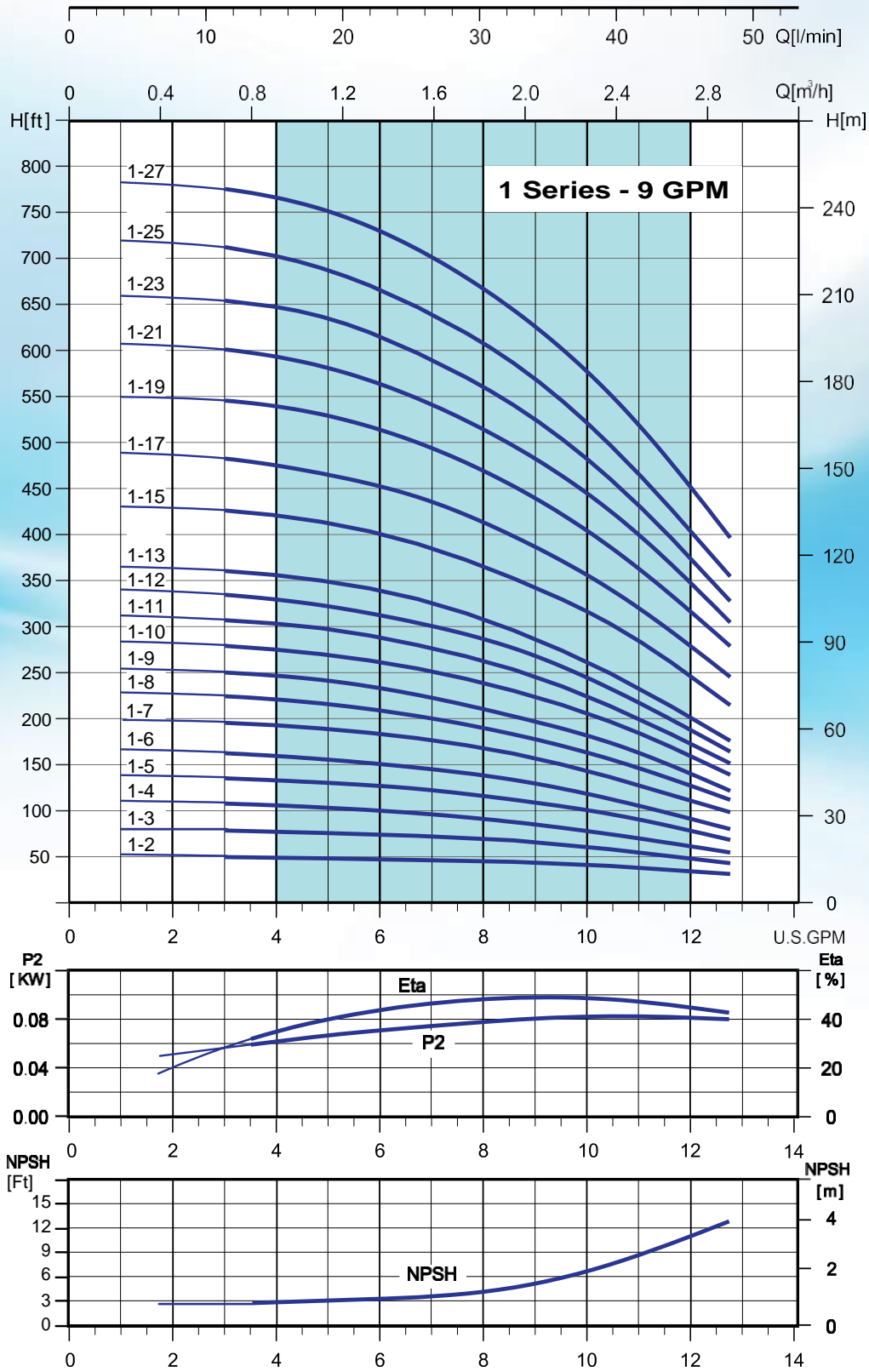

## Peso y dimensiones

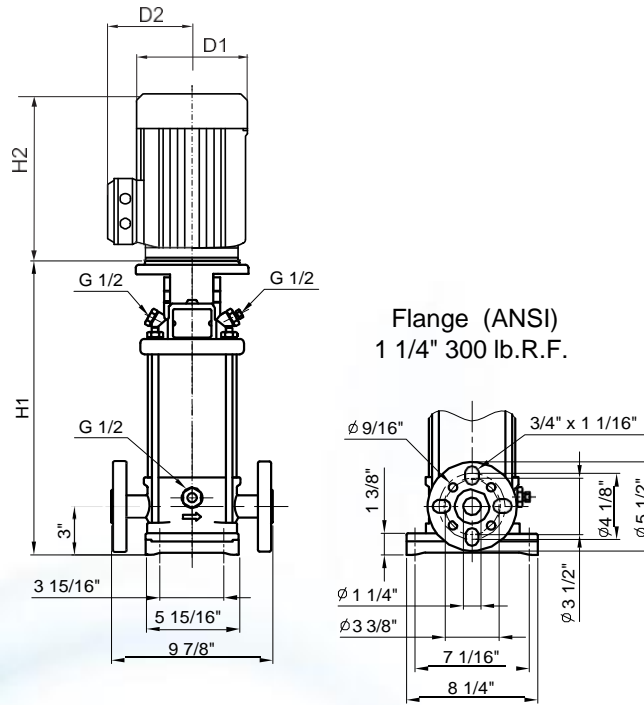

MODELO	HP	ACOPLE	MOTOR ODP	MOTOR TEFC	DIMENSIONES Y PESO SERIE VPS - MOTORES NEMA																PESO NETO		PESO NETO			
					H1		H2		H2		D1		D1		D2		D2		D3		D3		ODP	TEFC	ODP	TEFC
					HIDRAULICA		ODP		TEFC		ODP		TEFC		ODP		TEFC		ODP		TEFC					
					in	mm	in	mm	in	mm	in	mm	in	mm	in	mm	in	mm	in	mm	in	mm	in	mm	lbs	kg
<b>MONOFASICA</b>																										
VPS 1-2	0.5	56C	MVB 05F16O	MVB 05F16T	12 1/8	306	10	249	9 1/4	233	6 1/4	158	6 1/4	158	5 1/8	129	5 1/4	132	6	150	6	148	52	24	51	24
VPS 1-3	0.5	56C	MVB 05F16O	MVB 05F16T	12 1/8	306	10	249	9 1/4	233	6 1/4	158	6 1/4	158	5 1/8	129	5 1/4	132	6	150	6	148	54	25	53	25
VPS 1-4	0.5	56C	MVB 05F16O	MVB 05F16T	13	324	10	249	9 1/4	233	6 1/4	158	6 1/4	158	5 1/8	129	5 1/4	132	6	150	6	148	54	25	53	25
VPS 1-5	0.5	56C	MVB 05F16O	MVB 05F16T	13 1/2	342	10	249	9 1/4	233	6 1/4	158	6 1/4	158	5 1/8	129	5 1/4	132	6	150	6	148	57	26	56	26
VPS 1-6	0.75	56C	MVB 07F16O	MVB 07F16T	14 1/4	360	10 5/8	270	10	249	6 1/4	158	6 1/4	158	5 1/8	129	5 1/4	132	6	148	6	148	72	33	62	29
VPS 1-7	0.75	56C	MVB 07F16O	MVB 07F16T	15	377	10 5/8	270	10	249	6 1/4	158	6 1/4	158	5 1/8	129	5 1/4	132	6	148	6	148	76	35	66	30
VPS 1-8	1	56C	MVB 10F16O	MVB 10F16T	15 5/8	395	11 1/4	284	10 1/8	256	6 5/8	169	7 1/4	183	5 3/4	145	5 3/4	147	6 1/2	165	6 1/2	165	82	38	75	35
VPS 1-9	1	56C	MVB 10F16O	MVB 10F16T	16 1/4	413	11 1/4	284	10 1/8	256	6 5/8	169	7 1/4	183	5 3/4	145	5 3/4	147	6 1/2	165	6 1/2	165	82	38	75	35
VPS 1-10	1	56C	MVB 10F16O	MVB 10F16T	17	431	11 1/4	284	10 1/8	256	6 5/8	169	7 1/4	183	5 3/4	145	5 3/4	147	6 1/2	165	6 1/2	165	83	38	76	35
VPS 1-11	1.5	56C	MVB 15F16O	MVB 15F16T	17 3/4	449	11 1/4	284	11 1/8	281	7 1/4	183	7 1/4	183	5 3/4	145	5 3/4	147	6 1/2	165	6 1/2	165	92	42	80	37
VPS 1-12	1.5	56C	MVB 15F16O	MVB 15F16T	18 1/2	467	11 1/4	284	11 1/8	281	7 1/4	183	7 1/4	183	5 3/4	145	5 3/4	147	6 1/2	165	6 1/2	165	92	42	80	37
VPS 1-13	1.5	56C	MVB 15F16O	MVB 15F16T	19 1/8	485	11 1/4	284	11 1/8	281	7 1/4	183	7 1/4	183	5 3/4	145	5 3/4	147	6 1/2	165	6 1/2	165	95	44	83	38
VPS 1-15	2	56C	MVB 20F16O	MVB 20F16T	20 5/8	522	11 1/4	284	12	304	7 1/4	183	7 1/4	183	5 3/4	145	5 3/4	146	6 1/2	165	6 1/2	165	112	51	96	44
VPS 1-17	2	56C	MVB 20F16O	MVB 20F16T	22	558	11 1/4	284	12	304	7 1/4	183	7 1/4	183	5 3/4	145	5 3/4	146	6 1/2	165	6 1/2	165	113	52	97	44
VPS 1-19	2	56C	MVB 20F16O	MVB 20F16T	23 1/2	595	11 1/4	284	12	304	7 1/4	183	7 1/4	183	5 3/4	145	5 3/4	146	6 1/2	165	6 1/2	165	115	53	99	45
VPS 1-21	3	182TC	MVB 30F16O	MVB 30F16T	25 3/4	654	12 1/2	316	13 3/4	348	9	227	8 5/8	219	5 5/8	143	7	175	9 1/8	230	9	226	111	51	123	56
VPS 1-23	3	182TC	MVB 30F16O	MVB 30F16T	27 1/4	690	12 1/2	316	13 3/4	348	9	227	8 5/8	219	5 5/8	143	7	175	9 1/8	230	9	226	113	52	125	57
VPS 1-25	3	182TC	MVB 30F16O	MVB 30F16T	28 5/8	726	12 1/2	316	13 3/4	348	9	227	8 5/8	219	5 5/8	143	7	175	9 1/8	230	9	226	115	53	127	58
VPS 1-27	3	182TC	MVB 30F16O	MVB 30F16T	30	762	12 1/2	316	13 3/4	348	9	227	8 5/8	219	5 5/8	143	7	175	9 1/8	230	9	226	117	54	129	59
<b>TRIFASICA</b>																										
VPS 1-2	0.5	56C	MVB 05H36O	MVB 05H36T	12 1/8	306	9 1/4	233	9 3/8	236	6 1/4	158	6 1/4	158	5 1/8	129	5 1/4	132	6	150	6	148	52	24	48	22
VPS 1-3	0.5	56C	MVB 05H36O	MVB 05H36T	12 1/8	306	9 1/4	233	9 3/8	236	6 1/4	158	6 1/4	158	5 1/8	129	5 1/4	132	6	150	6	148	54	25	50	23
VPS 1-4	0.5	56C	MVB 05H36O	MVB 05H36T	13	324	9 1/4	233	9 3/8	236	6 1/4	158	6 1/4	158	5 1/8	129	5 1/4	132	6	150	6	148	54	25	50	23
VPS 1-5	0.5	56C	MVB 05H36O	MVB 05H36T	13 1/2	342	9 1/4	233	9 3/8	236	6 1/4	158	6 1/4	158	5 1/8	129	5 1/4	132	6	150	6	148	57	26	53	25
VPS 1-6	0.75	56C	MVB 07H36O	MVB 07H36T	14 1/4	360	9 1/4	233	9 3/8	236	6 1/4	158	6 1/4	158	5 1/8	129	5 1/4	132	6	150	6	148	58	27	54	25
VPS 1-7	0.75	56C	MVB 07H36O	MVB 07H36T	15	377	9 1/4	233	9 3/8	236	6 1/4	158	6 1/4	158	5 1/8	129	5 1/4	132	6	150	6	148	62	29	58	27
VPS 1-8	1	56C	MVB 10H36O	MVB 10H36T	15 5/8	395	10	249	10 1/4	259	6 1/4	158	7	179	5 1/8	129	5 3/4	147	6	150	6 1/2	165	66	30	71	33
VPS 1-9	1	56C	MVB 10H36O	MVB 10H36T	16 1/4	413	10	249	10 1/4	259	6 1/4	158	7	179	5 1/8	129	5 3/4	147	6	150	6 1/2	165	66	30	71	33
VPS 1-10	1	56C	MVB 10H36O	MVB 10H36T	17	431	10	249	10 1/4	259	6 1/4	158	7	179	5 1/8	129	5 3/4	147	6	150	6 1/2	165	67	31	72	33
VPS 1-11	1.5	56C	MVB 15H36O	MVB 15H36T	17 3/4	449	10 1/4	259	10 1/4	259	7 1/4	183	7	179	5 5/8	143	5 3/4	147	6 1/2	165	6 1/2	165	74	34	75	35
VPS 1-12	1.5	56C	MVB 15H36O	MVB 15H36T	18 1/2	467	10 1/4	259	10 1/4	259	7 1/4	183	7	179	5 5/8	143	5 3/4	147	6 1/2	165	6 1/2	165	74	34	75	35
VPS 1-13	1.5	56C	MVB 15H36O	MVB 15H36T	19 1/8	485	10 1/4	259	10 1/4	259	7 1/4	183	7	179	5 5/8	143	5 3/4	147	6 1/2	165	6 1/2	165	77	35	78	36
VPS 1-15	2	56C	MVB 20H36O	MVB 20H36T	20 5/8	522	11 1/4	284	11 1/4	284	7 1/4	183	7	179	5 5/8	143	5 3/4	147	6 1/2	165	6 1/2	165	89	41	89	41
VPS 1-17	2	56C	MVB 20H36O	MVB 20H36T	22	558	11 1/4	284	11 1/4	284	7 1/4	183	7	179	5 5/8	143	5 3/4	147	6 1/2	165	6 1/2	165	90	41	90	41
VPS 1-19	2	56C	MVB 20H36O	MVB 20H36T	23 1/2	595	11 1/4	284	11 1/4	284	7 1/4	183	7	179	5 5/8	143	5 3/4	147	6 1/2	165	6 1/2	165	92	42	92	42
VPS 1-21	3	182TC	-	MVB 30H36T	25 3/4	654	-	-	12 1/2	316	-	-	7 1/4	183	-	-	5 3/4	146	-	-	9	226	-	-	100	46
VPS 1-23	3	182TC	-	MVB 30H36T	27 1/4	690	-	-	12 1/2	316	-	-	7 1/4	183	-	-	5 3/4	146	-	-	9	226	-	-	102	47
VPS 1-25	3	182TC	-	MVB 30H36T	28 5/8	726	-	-	12 1/2	316	-	-	7 1/4	183	-	-	5 3/4	146	-	-	9	226	-	-	104	48
VPS 1-27	3	182TC	-	MVB 30H36T	30	762	-	-	12 1/2	316	-	-	7 1/4	183	-	-	5 3/4	146	-	-	9	226	-	-	106	49

- No está disponible  
Todas las medidas son de referencia. Los valores podrán cambiar según el modelo del motor.